

## IEEE 802.3-2005 PoE INTERFACE AND ISOLATED CONVERTER CONTROLLER

### FEATURES

- Optimized for Isolated Converters
- Complete PoE Interface
- Adapter ORing Support
- 12 V Adapter Support
- Programmable Frequency with Synch.
- Robust 100 V, 0.7  $\Omega$  Hotswap MOSFET
- Small TSSOP 14 Package
- 15 kV / 8 kV System Level ESD Capable
- $-40^{\circ}\text{C}$  to  $125^{\circ}\text{C}$  Junction Temperature Range
- Design Procedure Application Note - [SLVA305](#)
- Adapter ORing Application Note - [SLVA306](#)

### APPLICATIONS

- IEEE 802.3-2005 Compliant Powered Devices
- VoIP Telephones
- Access Points
- Security Cameras

### DESCRIPTION

The TPS23753 is a combined Power over Ethernet (PoE) powered device (PD) interface and current-mode dc/dc controller optimized specifically for isolated converter designs. The PoE implementation supports the IEEE 802.3-2005 (previously 802.3af) standard, 12.95 W (13 W) PD.

The TPS23753 supports a number of input-voltage ORing options including highest voltage, external adapter preference, and PoE preference.

The PoE interface features an external detection signature pin that can also be used to disable the internal hotswap MOSFET. This allows the PoE function to be turned off. Classification can be programmed to any of the defined types with a single resistor.

The dc/dc controller features a bootstrap startup mechanism with an internal, switched current source. This provides the advantages of cycling overload fault protection without the constant power loss of a pull up resistor.

The programmable oscillator may be synchronized to a higher-frequency external timing reference.

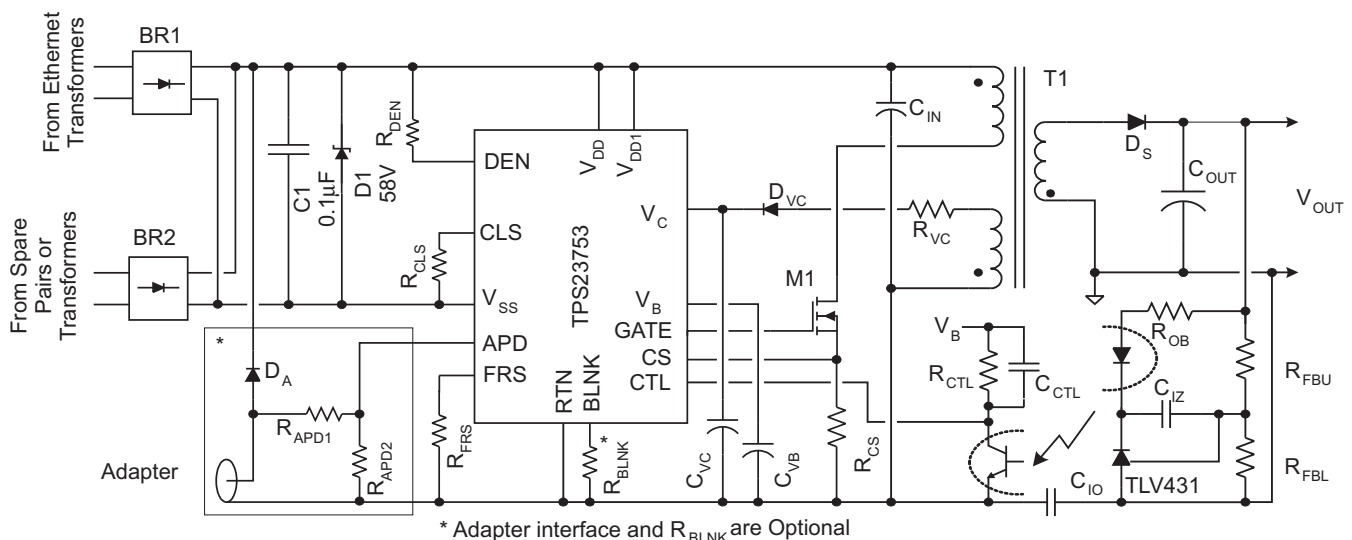

**Figure 1. Basic TPS23753 Implementation**



Please be aware that an important notice concerning availability, standard warranty, and use in critical applications of Texas Instruments semiconductor products and disclaimers thereto appears at the end of this data sheet.



This device contains circuits to protect its inputs and outputs against damage due to high static voltages or electrostatic fields. These circuits have been qualified to protect this device against electrostatic discharges (ESD) of up to 2 kV according to MIL-STD-883C, Method 3015; however, it is advised that precautions be taken to avoid application of any voltage higher than maximum-rated voltages to these high-impedance circuits. During storage or handling the device leads should be shorted together or the device should be placed in conductive foam. In a circuit, unused inputs should always be connected to an appropriate logic voltage level, preferably either  $V_{CC}$  or ground. Specific guidelines for handling devices of this type are contained in the publication Guidelines for Handling Electrostatic-Discharge-Sensitive (ESDS) Devices and Assemblies available from Texas Instruments.

### PRODUCT INFORMATION<sup>(1)</sup>

DEVICE	DUTY CYCLE	POE UVLO ON / HYST.	PACKAGE	MARKING
TPS23753	0 – 80%	35/4.5	PW (TSSOP-14)	TP23753

- (1) For the most current package and ordering information, see the Package Option Addendum at the end of this document, or see the TI website at [www.ti.com](http://www.ti.com).

### ABSOLUTE MAXIMUM RATINGS<sup>(1)</sup>

Voltages are with respect to  $V_{SS}$  (unless otherwise noted)

			VALUE	UNIT
$V_I$	Input voltage range	$V_{DD}, V_{DD1}, DEN, RTN$ <sup>(2)</sup>	–0.3 to 100	V
		$V_{DD1}$ to RTN	–0.3 to 100	V
		CLS <sup>(3)</sup>	–0.3 to 6.5	V
		[APD, BLNK <sup>(3)</sup> , CTL, FRS <sup>(3)</sup> , $V_B$ <sup>(3)</sup> ] to RTN	–0.3 to 6.5	V
		CS to RTN	–0.3 to $V_B$	V
		$V_C$ to RTN	–0.3 to 19	V
		GATE to RTN	–0.3 to $V_C + 0.3$	V
Sourcing current		$V_B$	Internally limited	mA
Average sourcing or sinking current		GATE	25	$mA_{RMS}$
ESD rating	HBM		2	kV
	CDM		500	V
ESD – system level (contact/air) <sup>(4)</sup>			8/15	kV
$T_J$	Operating junction temperature range		–40 to Internally Limited	°C

- (1) Stresses beyond those listed under *absolute maximum ratings* may cause permanent damage to the device. These are stress ratings only, and functional operation of the device at these or any other conditions beyond those indicated under *recommended operating conditions* is not implied. Exposure to absolute-maximum-rated conditions for extended periods may affect device reliability.
- (2)  $I_{RTN} = 0$  for  $V_{RTN} > 80V$ .
- (3) Do not apply voltage to these pins.
- (4) Surges per EN61000-4-2, 1999 applied between RJ-45 and output ground and between adapter input and output ground of the TPS23753EVM-001 (HPA304-001) evaluation module (documentation available on the web). These were the test levels, not the failure threshold.

### DISSIPATION RATINGS

PACKAGE	$\theta_{JT}$ (°C/W) <sup>(1)</sup>	$\theta_{JA}$ (°C/W) <sup>(2)</sup>	$\theta_{JA}$ (°C/W) <sup>(1)</sup>
PW (TSSOP-14)	0.97	173.6	99.3

- (1) JEDEC method with high-k board (4 layers, 2 signal and 2 planes).
- (2) JEDEC method with low-k board (2 signal layers).

## RECOMMENDED OPERATING CONDITIONS

 Voltage with respect to  $V_{SS}$  (unless otherwise noted)

		MIN	NOM	MAX	UNIT
$V_I$	Input voltage range, $V_{DD}$ , $V_{DD1}$ , RTN	0		57	V
	Input voltage range, $V_{DD}$ , $V_{DD1}$ to RTN	0		57	V
	Input voltage range, $V_C$ to RTN	0		18	V
	Input voltage range, APD, CTL to RTN	0		$V_B$	V
	Input voltage range, CS to RTN	0		2	V
RTN current ( $T_J \leq 125^\circ\text{C}$ )				350	mA
$V_B$ sourcing current		0	2.5	5	mA
$V_B$ capacitance		0.08	0.1	2.2	$\mu\text{F}$
$R_{BLNK}$		0		350	k $\Omega$
Synchronization pulse width input (when used)		25		150	ns
$T_J$	Operating junction temperature range	-40		125	$^\circ\text{C}$

## ELECTRICAL CHARACTERISTICS

 Unless otherwise noted: CS = APD = CTL = RTN, GATE open,  $R_{FRS} = 60.4\text{ k}\Omega$ ,  $R_{BLNK} = 249\text{ k}\Omega$ ,  $C_{VB} = C_{VC} = 0.1\text{ }\mu\text{F}$ ,  $R_{DEN} = 24.9\text{ k}\Omega$ ,  $R_{CLS}$  open,  $V_{VDD-VSS} = 48\text{ V}$ ,  $V_{VDD1-RTN} = 48\text{ V}$ ,  $8.5\text{ V} \leq V_{VC-RTN} \leq 18\text{ V}$ ,  $-40^\circ\text{C} \leq T_J \leq 125^\circ\text{C}$ 

### Controller Section Only

 $[V_{SS} = \text{RTN and } V_{DD} = V_{DD1}]$  or  $[V_{SS} = \text{RTN} = V_{DD}]$ , all voltages referred to RTN. Typical specifications are at  $25^\circ\text{C}$ .

PARAMETER		TEST CONDITIONS	MIN	TYP	MAX	UNIT
<b><math>V_C</math></b>						
UVLO <sub>I</sub>	Undervoltage lockout	$V_C$ rising	8.65	9	9.3	V
UVLO <sub>H</sub>		Hysteresis <sup>(1)</sup>	3.3	3.5	3.7	
Operating current		$V_C = 12\text{ V}$ , CTL = $V_B$	0.40	0.58	0.85	mA
$t_{ST}$	Startup time, $C_{VC} = 22\text{ }\mu\text{F}$	$V_{DD1} = 10.2\text{ V}$ , $V_C(0) = 0\text{ V}$	50	85	175	ms
		$V_{DD1} = 35\text{ V}$ , $V_C(0) = 0\text{ V}$	30	48	85	
	Startup current source - $I_{VC}$	$V_{DD1} = 10.2\text{ V}$ , $V_{VC} = 8.6\text{ V}$	0.44	1.06	1.80	mA
		$V_{DD1} = 48\text{ V}$ , $V_{VC} = 0\text{ V}$	2.5	4.3	6.0	
<b><math>V_B</math></b>						
Voltage		$6.5\text{ V} \leq V_C \leq 18\text{ V}$ , $0 \leq I_{VB} \leq 5\text{ mA}$	4.75	5.10	5.25	V
<b>FRS</b>						
Switching frequency		CTL = $V_B$ , Measure GATE $R_{FRS} = 60.4\text{ k}\Omega$	223	248	273	kHz
$D_{MAX}$	Duty cycle	CTL = $V_B$ , Measure GATE	76	78.5	81	%
$V_{SYNC}$	Synchronization	Input threshold	2.0	2.2	2.4	V
<b>CTL</b>						
$V_{ZDC}$	0% duty cycle threshold	$V_{CTL} \downarrow$ until GATE stops	1.3	1.5	1.7	V
Softstart period		Interval from switching start to $V_{CSMAX}$	400	800		$\mu\text{s}$
Input resistance			70	100	145	k $\Omega$
<b>BLNK</b>						
Blanking delay		In addition to $t_1$ BLNK = RTN $R_{BLNK} = 49.9\text{ k}\Omega$	35	52	75	ns
			41	52	63	
<b>CS</b>						
$V_{CSMAX}$	Maximum threshold voltage	$V_{CTL} = V_B$ , $V_{CS} \uparrow$ until GATE duty cycle drops	0.50	0.55	0.60	V
$t_1$	Turn off delay	$V_{CS} = 0.65\text{ V}$	25	41	60	ns
$V_{SLOPE}$	Internal slope compensation voltage	Peak voltage at maximum duty cycle, referred to CS	90	118	142	mV
$I_{SL\_EX}$	Peak slope compensation current	$V_{CTL} = V_B$ , $I_{CS}$ at maximum duty cycle (ac component)	30	42	54	$\mu\text{A}$
Bias current (sourcing)		Gate high, dc component of CS current	2	3	4.2	$\mu\text{A}$

(1) The hysteresis tolerance tracks the rising threshold for a given device.

### ELECTRICAL CHARACTERISTICS (continued)

Unless otherwise noted: CS = APD = CTL = RTN, GATE open, R<sub>FRS</sub> = 60.4 kΩ, R<sub>BLNK</sub> = 249 kΩ, C<sub>VB</sub> = C<sub>VC</sub> = 0.1 μF, R<sub>DEN</sub> = 24.9 kΩ, R<sub>CLS</sub> open, V<sub>VDD-VSS</sub> = 48 V, V<sub>VDD1-RTN</sub> = 48 V, 8.5 V ≤ V<sub>VC-RTN</sub> ≤ 18 V, -40°C ≤ T<sub>J</sub> ≤ 125°C

#### Controller Section Only

[V<sub>SS</sub> = RTN and V<sub>DD</sub> = V<sub>DD1</sub>] or [V<sub>SS</sub> = RTN = V<sub>DD</sub>], all voltages referred to RTN. Typical specifications are at 25°C.

PARAMETER		TEST CONDITIONS	MIN	TYP	MAX	UNIT
<b>GATE</b>						
Source current		V <sub>CTL</sub> = V <sub>B</sub> , V <sub>C</sub> = 12 V, GATE high, Pulsed measurement	0.30	0.46	0.60	A
Sink current		V <sub>CTL</sub> = V <sub>B</sub> , V <sub>C</sub> = 12 V, GATE low, Pulsed measurement	0.50	0.79	1.1	A
<b>APD</b>						
V <sub>APDEN</sub>	Threshold voltage	V <sub>APD</sub> ↑	1.42	1.5	1.58	V
V <sub>APDH</sub>		Hysteresis <sup>(2)</sup>	0.28	0.3	0.32	
<b>THERMAL SHUTDOWN</b>						
Turn off temperature			135	145	155	°C
Hysteresis <sup>(3)</sup>				20		°C

(2) The hysteresis tolerance tracks the rising threshold for a given device.

(3) These parameters are provided for reference only, and do not constitute part of TI's published device specifications for purposes of TI's product warranty.

### ELECTRICAL CHARACTERISTICS

#### PoE and Control

[V<sub>DD</sub> = V<sub>DD1</sub>] or [V<sub>DD1</sub>] = RTN, V<sub>VC-RTN</sub> = 0 V, all voltages referred to V<sub>SS</sub>. Typical specifications are at 25°C.

PARAMETER		TEST CONDITIONS	MIN	TYP	MAX	UNIT
<b>DEN (DETECTION)</b>						
(V <sub>DD</sub> = V <sub>DD1</sub> = RTN = V <sub>SUPPLY</sub> positive)						
Detection current	Measure I <sub>SUPPLY</sub>					μA
	V <sub>DD</sub> = 1.6 V		62	64.3	66.5	
	V <sub>DD</sub> = 10 V		399	406	413	
Detection bias current		V <sub>DD</sub> = 10 V, DEN open, Measure I <sub>SUPPLY</sub>		5.2	12	μA
V <sub>PD_DIS</sub>	Hotswap disable threshold		3	4	5	V
I <sub>lkg</sub>	DEN leakage current	V <sub>DEN</sub> = V <sub>DD</sub> = 57 V, Float V <sub>DD1</sub> and RTN, Measure I <sub>DEN</sub>		0.1	5	μA
<b>CLS (CLASSIFICATION)</b>						
(V <sub>DD</sub> = V <sub>DD1</sub> = RTN = V <sub>SUPPLY</sub> positive)						
I <sub>CLS</sub>	Classification current	13 V ≤ V <sub>DD</sub> ≤ 21 V, Measure I <sub>SUPPLY</sub>				mA
		R <sub>CLS</sub> = 1270 Ω	1.8	2.14	2.4	
		R <sub>CLS</sub> = 243 Ω	9.9	10.6	11.3	
		R <sub>CLS</sub> = 137 Ω	17.6	18.6	19.4	
		R <sub>CLS</sub> = 90.9 Ω	26.5	27.9	29.3	
		R <sub>CLS</sub> = 63.4 Ω	38	39.9	42	
V <sub>CL_ON</sub>	Classification regulator lower threshold	Regulator turns on, V <sub>DD</sub> rising	10	11.7	13	V
V <sub>CL_HYS</sub>		Hysteresis <sup>(1)</sup>	1.9	2.05	2.2	
V <sub>CU_OFF</sub>	Classification regulator upper threshold	Regulator turns off, V <sub>DD</sub> rising	21	22	23	V
V <sub>CU_HYS</sub>		Hysteresis <sup>(1)</sup>	0.5	0.77	1	
I <sub>lkg</sub>	Leakage current	V <sub>DD</sub> = 57 V, V <sub>CLS</sub> = 0 V, DEN = V <sub>SS</sub> , Measure I <sub>CLS</sub>			1	μA
<b>RTN (PASS DEVICE)</b>						
(V <sub>DD1</sub> = RTN)						
On resistance				0.7	1.2	Ω
Current limit		V <sub>RTN</sub> = 1.5 V, V <sub>DD</sub> = 48 V, Pulsed Measurement	405	450	505	mA
Inrush limit		V <sub>RTN</sub> = 2 V, V <sub>DD</sub> : 0 V → 48 V, Pulsed Measurement	100	140	180	mA
Foldback voltage threshold		V <sub>DD</sub> rising	11	12.3	13.6	V
I <sub>lkg</sub>	Leakage current	V <sub>DD</sub> = V <sub>RTN</sub> = 100 V, DEN = V <sub>SS</sub>			40	μA
<b>UVLO</b>						
UVLO_R	Undervoltage lockout threshold	V <sub>DD</sub> rising	33.9	35	36.1	V
UVLO_H		Hysteresis <sup>(1)</sup>	4.40	4.55	4.70	

(1) The hysteresis tolerance tracks the rising threshold for a given device.

## ELECTRICAL CHARACTERISTICS (continued)

### PoE and Control

[V<sub>DD</sub> = V<sub>DD1</sub>] or [V<sub>DD1</sub>] = RTN, V<sub>VC-RTN</sub> = 0 V, all voltages referred to V<sub>SS</sub>. Typical specifications are at 25°C.

PARAMETER	TEST CONDITIONS	MIN	TYP	MAX	UNIT
<b>THERMAL SHUTDOWN</b>					
Turn off temperature		135	145	155	°C
Hysteresis <sup>(2)</sup>			20		°C

(2) These parameters are provided for reference only, and do not constitute part of TI's published device specifications for purposes of TI's product warranty.

## DEVICE INFORMATION

### TOP VIEW

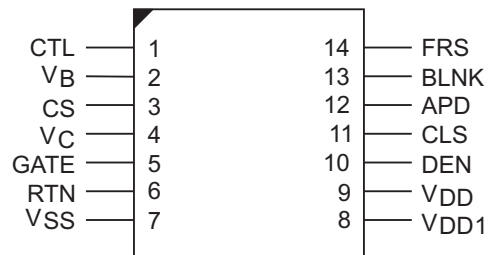

**Table 1. Terminal Functions**

TERMINAL		I/O	DESCRIPTION
NO.	NAME		
1	CTL	I	The control loop input to the PWM (pulse width modulator). Use V <sub>B</sub> as a pull up for CTL.
2	V <sub>B</sub>	O	5 V bias rail for dc/dc control circuits. Apply a 0.1 μF to RTN. V <sub>B</sub> may be used to bias an external optocoupler for feedback.
3	CS	I	Dc/dc converter switching MOSFET current sense input. Connect CS to the high side of the RTN-referenced current sense resistor.
4	V <sub>C</sub>	I/O	Dc/dc converter bias voltage. The internal startup current source and converter bias winding output power this pin. Connect a 0.22 μF minimum ceramic capacitor to RTN, and a larger capacitor to facilitate startup.
5	GATE	O	Gate drive output for the dc/dc converter switching MOSFET.
6	RTN		RTN is the negative rail input to the dc/dc converter and output of the PoE hotswap.
7	V <sub>SS</sub>		Negative power rail derived from the PoE source.
8	V <sub>DD1</sub>		Source of dc/dc converter startup current. Connect to V <sub>DD</sub> for most applications.
9	V <sub>DD</sub>		Positive input power rail for PoE interface circuit. Derived from the PoE source.
10	DEN	I/O	Connect a 24.9 kΩ resistor from DEN to V <sub>DD</sub> to provide the PoE detection signature. Pulling this pin to V <sub>SS</sub> during powered operation causes the internal hotswap MOSFET to turn off.
11	CLS	O	Connect a resistor from CLS to V <sub>SS</sub> to program the classification current per <a href="#">Table 2</a> .
12	APD	I	Pull APD above 1.5 V to disable the internal PD hotswap switch, forcing power to come from an external adapter. Connect to the adapter through a resistor divider.
13	BLNK	I/O	Connect to RTN to utilize the internally set blanking period or connect through a resistor to RTN to program the blanking period.
14	FRS	I/O	Connect a resistor from FRS to RTN to program the converter switching frequency.

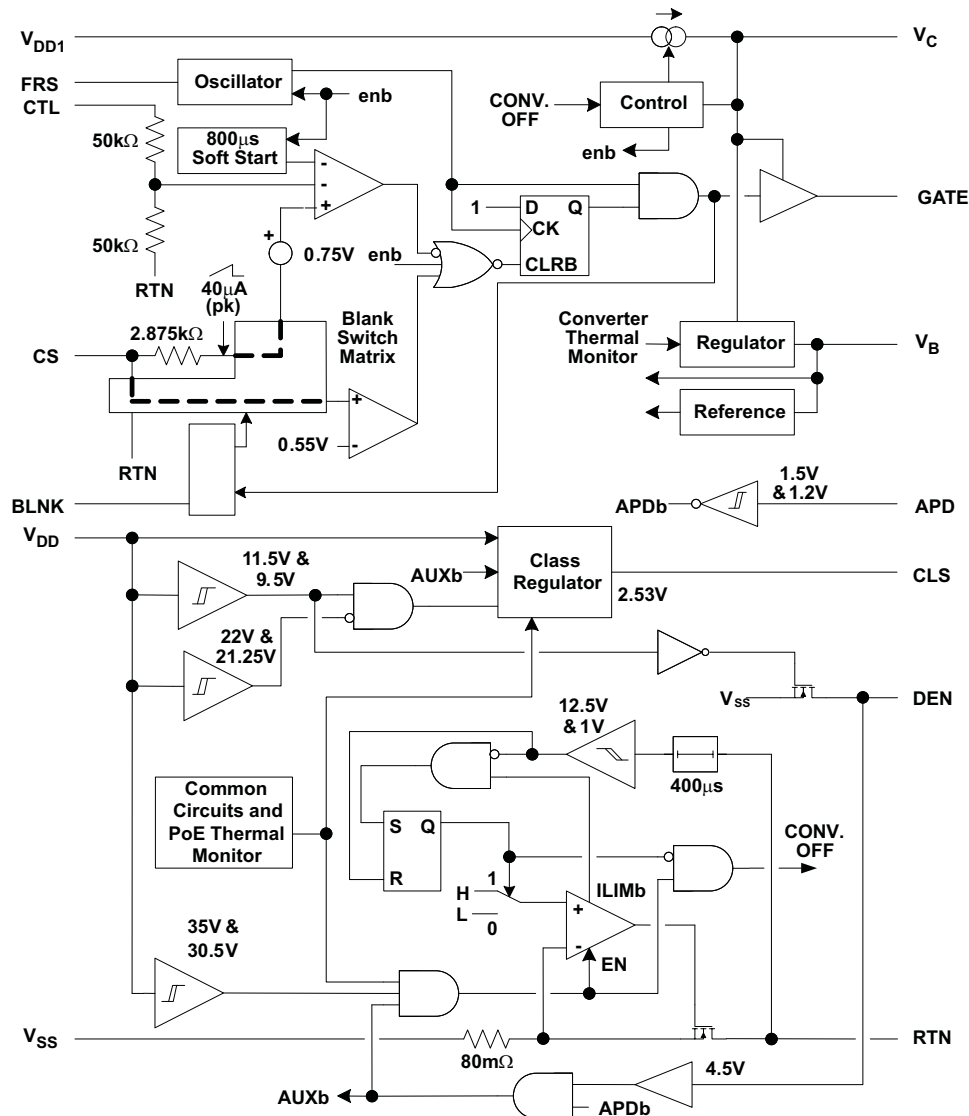

Figure 2. TPS23753 Functional Block Diagram

### Pin Description

Refer to [Figure 1](#) for component reference designators ( $R_{CS}$  for example), and the Electrical Characteristics table for values denoted by reference ( $V_{CSMAX}$  for example). Electrical Characteristic values take precedence over any numerical values used in the following sections.

### APD

APD forces power to come from an external adapter connected from  $V_{DD1}$  to RTN by opening the hotswap switch. A resistor divider is recommended on APD when it is connected to an external adapter. The divider provides ESD protection, leakage discharge for the adapter ORing diode, and input voltage qualification. Voltage qualification assures the adapter can support the PD before the PoE current is cut off.

Select the APD divider resistors per the following equations where  $V_{ADPTR-ON}$  is the desired adapter voltage that enables the APD function as adapter voltage rises.

$$R_{APD1} = R_{APD2} \cdot (V_{ADPTR\_ON} - V_{APDEN}) / V_{APDEN} \quad (1)$$

$$V_{ADPTR\_OFF} = \frac{R_{APD1} + R_{APD2}}{R_{APD2}} \cdot (V_{APDEN} - V_{APDH}) \quad (2)$$

The CLS output is disabled when a voltage above  $V_{APDEN}$  is applied to the APD pin.

Place the APD pull-down resistor adjacent to the APD pin.

APD should be tied to RTN when not used.

### BLNK

Blanking provides an interval between the gate drive going high and the current comparator on CS actively monitoring the input. This delay allows the normal turn-on current transient (spike) to subside before the comparator is active, preventing undesired short duty cycles and premature current limiting.

Connect BLNK to RTN to obtain the internally set blanking period. Connect a resistor from BLNK to RTN for a programmable blanking period. The relationship between the desired blanking period and the programming resistor is defined by the following equation.

$$R_{BLNK} (k\Omega) = t_{BLNK} (ns) \quad (3)$$

Place the resistor adjacent to the BLNK pin when it is used.

### CLS

Connect a resistor from CLS to  $V_{SS}$  to program the classification current per IEEE 802.3-2005 and preliminary 802.3at specifications. The PD power ranges and corresponding resistor values are listed in [Table 2](#). The power assigned should correspond to the maximum average power drawn by the PD during operation. The TPS23753 supports class 0 – 3 power levels.

### CS

The current sense input for the dc/dc converter should be connected to the high side of the switching MOSFET's current sense resistor. The current-limit threshold,  $V_{CSMAX}$ , defines the voltage on CS above which the GATE ON time will be terminated regardless of the voltage on CTL.

The TPS23753 provides internal slope compensation to stabilize the current mode control loop. If the provided slope is not sufficient, the effective slope may be increased by addition of  $R_S$  per [Figure 22](#).

Routing between the current-sense resistor and the CS pin should be short to minimize cross-talk from noisy traces such as the gate drive signal.

### CTL

CTL is the voltage control loop input to the PWM (pulse width modulator). Pulling  $V_{CTL}$  below  $V_{ZDC}$  causes GATE to stop switching. Increasing  $V_{CTL}$  above  $V_{ZDC}$  raises the switching MOSFET programmed peak current. The maximum (peak) current is requested at approximately  $V_{ZDC} + (2 \times V_{CSMAX})$ . The ac gain from CTL to the PWM comparator is 0.5.

Use  $V_B$  as a pull up source for CTL.

### DEN

Connect a 24.9 k $\Omega$  resistor from DEN to  $V_{DD}$  to provide the PoE detection signature. DEN goes to a high impedance state when not in the detection voltage range. Pulling DEN to  $V_{SS}$  during powered operation causes the internal hotswap MOSFET and class regulator to turn off.

## FRS

Connect a resistor from FRS to RTN to program the converter switching frequency. Select the resistor per the following relationship.

$$R_{FRS} (k\Omega) = \frac{15000}{f_{SW} (kHz)} \quad (4)$$

The converter may be synchronized to a frequency above its maximum free-running frequency by applying short ac-coupled pulses into the FRS pin. More information is provided in the Applications section.

The FRS pin is high impedance. Keep the connections short and apart from potential noise sources.

## GATE

Gate drive output for the dc/dc converter switching MOSFET.

## RTN

RTN is internally connected to the drain of the PoE hotswap MOSFET, and the dc/dc controller return. RTN should be treated as a local reference plane (ground plane) for the dc/dc controller and converter primary to maintain signal integrity.

## V<sub>B</sub>

V<sub>B</sub> is an internal 5V control rail that should be bypassed by a 0.1 μF capacitor to RTN. V<sub>B</sub> should be used to bias the feedback optocoupler.

## V<sub>C</sub>

V<sub>C</sub> is the bias supply for the dc/dc controller. The MOSFET gate driver runs directly from V<sub>C</sub>. V<sub>B</sub> is regulated down from V<sub>C</sub>, and is the bias voltage for the rest of the converter control. A startup current source from V<sub>DD1</sub> to V<sub>C</sub> is controlled by a comparator with hysteresis to implement a bootstrap startup of the converter. V<sub>C</sub> must be connected to a bias source, such as a converter auxiliary output, during normal operation.

A minimum 0.22 μF capacitor, located adjacent to the V<sub>C</sub> pin, should be connected from V<sub>C</sub> to RTN to bypass the gate driver. A larger total capacitance is required for startup.

## V<sub>DD</sub>

Positive input power rail for PoE control that is derived from the PoE. V<sub>DD</sub> should be bypassed to V<sub>SS</sub> with a 0.1 μF (X7R, 10%) capacitor as required by the standard. A transient suppressor (Zener) diode, should be connected from V<sub>DD</sub> to V<sub>SS</sub> to protect against overvoltage transients.

## V<sub>DD1</sub>

Source of dc/dc converter startup current. Connect to V<sub>DD</sub> for most applications. V<sub>DD1</sub> may be isolated by a diode from V<sub>DD</sub> to support PoE priority operation.

## V<sub>SS</sub>

V<sub>SS</sub> is the PoE input-power return side. It is the reference for the PoE interface circuits, and has a current-limited hotswap switch that connects it to RTN. V<sub>SS</sub> is clamped to a diode drop above RTN by the hotswap switch. A local V<sub>SS</sub> reference plane should be used to connect the input components and the V<sub>SS</sub> pin.



TYPICAL CHARACTERISTICS

DETECTION BIAS CURRENT VS VOLTAGE

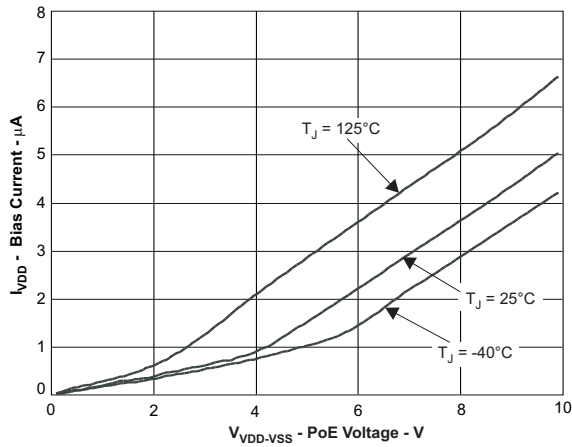

Figure 3.

PoE CURRENT LIMIT VS TEMPERATURE

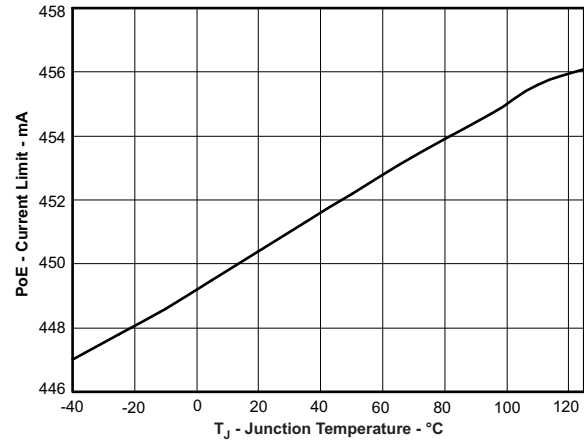

Figure 4.

CONVERTER START TIME VS TEMPERATURE

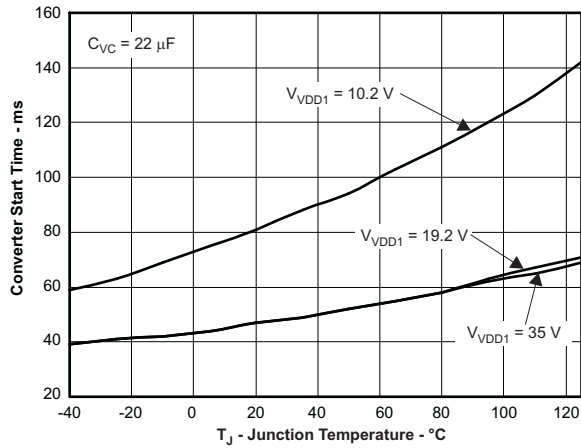

Figure 5.

CONVERTER STARTUP SOURCE CURRENT VS VDD1

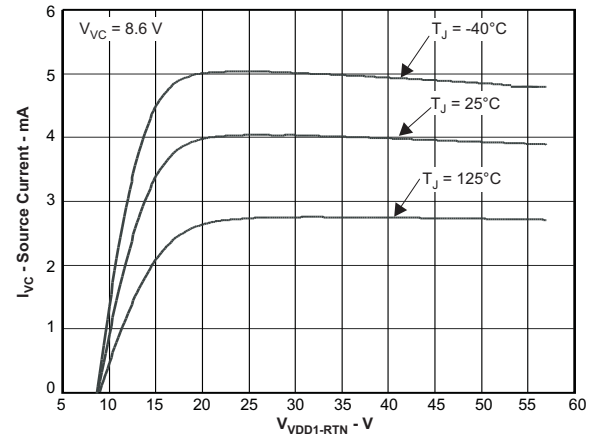

Figure 6.

CONTROLLER BIAS CURRENT VS TEMPERATURE

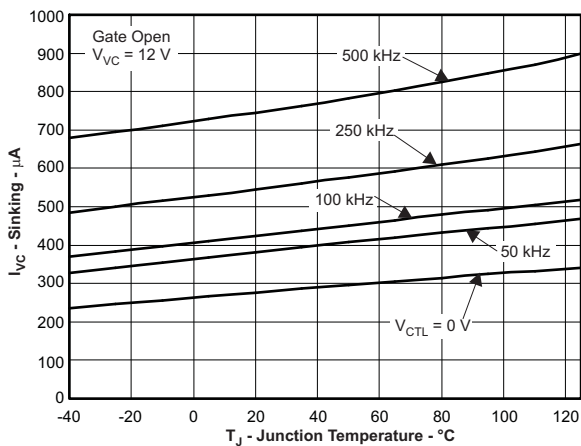

Figure 7.

CONTROLLER BIAS CURRENT VS VOLTAGE

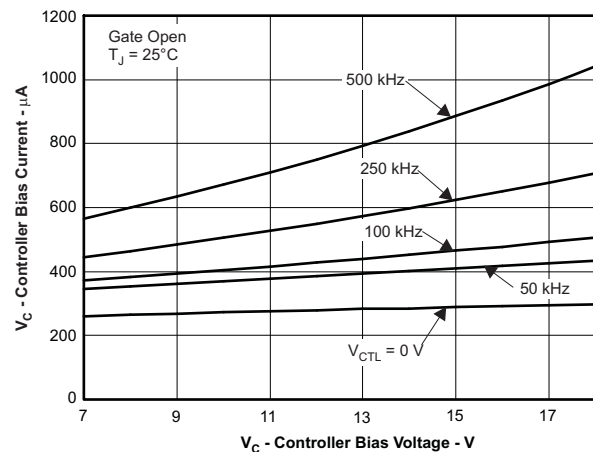

Figure 8.

TYPICAL CHARACTERISTICS (continued)

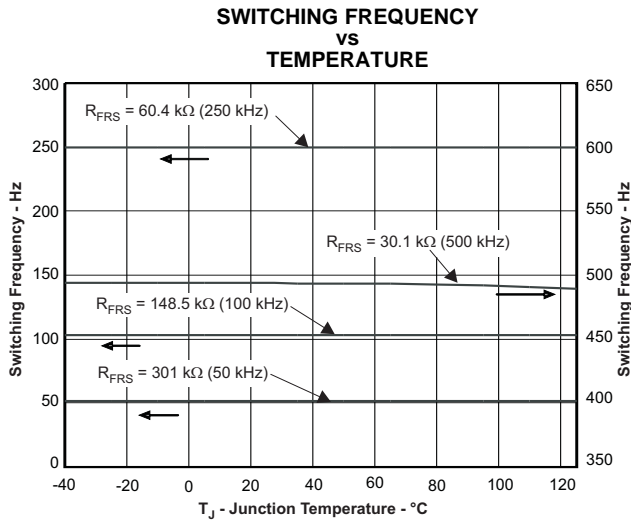

Figure 9.

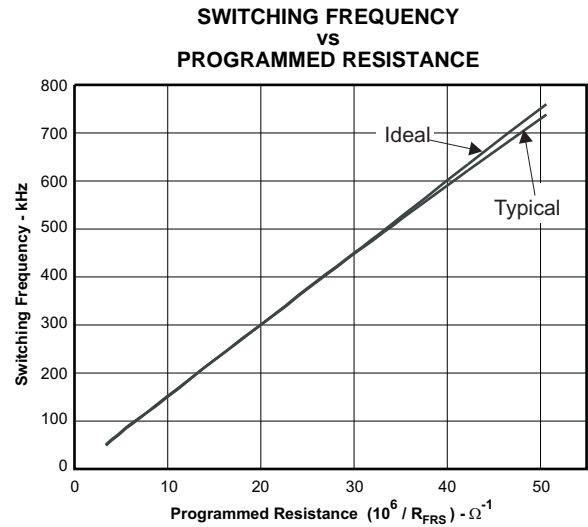

Figure 10.

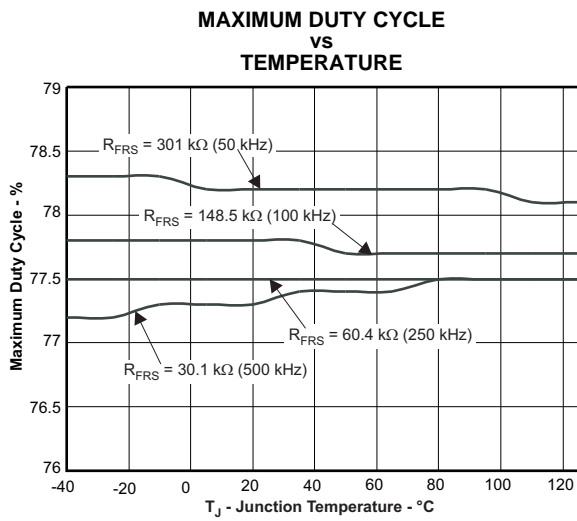

Figure 11.

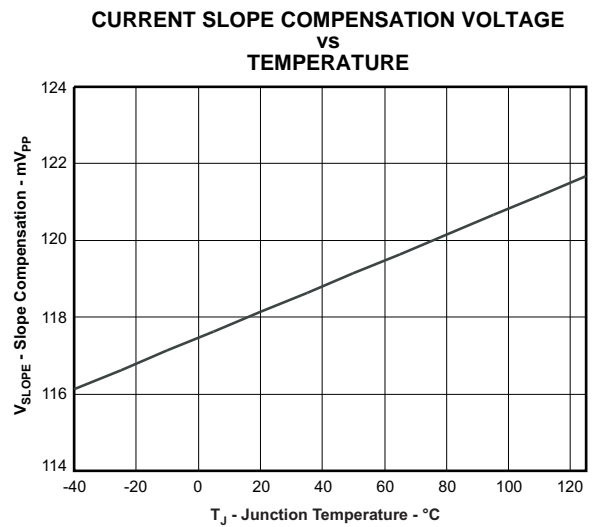

Figure 12.

TYPICAL CHARACTERISTICS (continued)

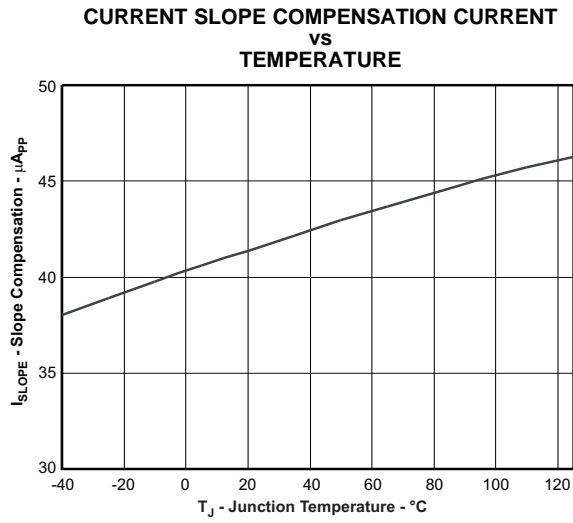

Figure 13.

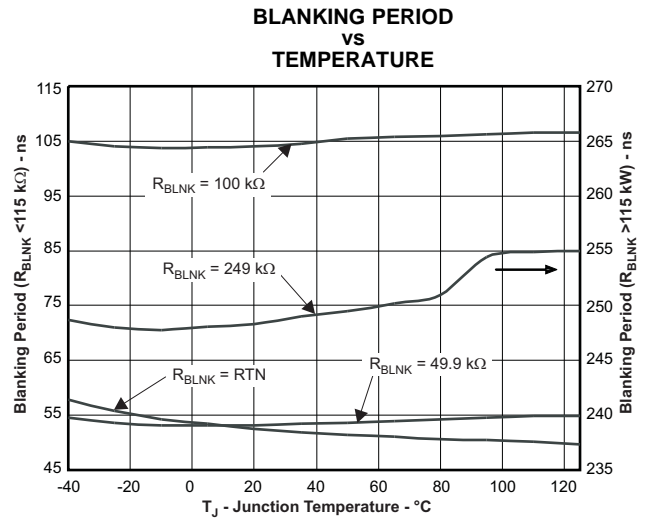

Figure 14.

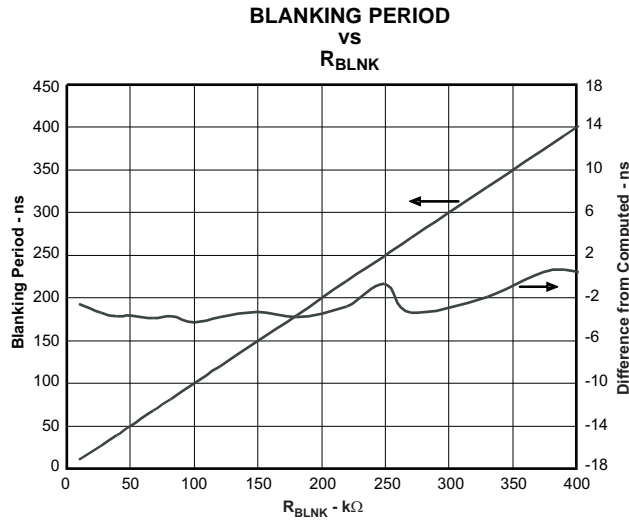

Figure 15.

## APPLICATIONS

### Classic PoE Overview

The following text is intended as an aid in understanding the operation of the TPS23753 but not as a substitute for the actual IEEE 802.3-2005 or 802.3at standard. The pending IEEE 802.3at standard is an update to IEEE 802.3-2005 clause 33 (PoE), adding high-power options and enhanced classification. Generally speaking, a device compliant to IEEE 802.3-2005 will be referred to as a Type 1 device, and devices with high power or enhanced classification will be referred to as Type 2 devices. Standards change and should always be referenced when making design decisions.

The IEEE 802.3-2005 (802.3at) standard defines a method of safely powering a PD (powered device) over a cable, and then removing power if a PD is disconnected. The process proceeds through an idle state and three operational states of detection, classification, and operation. The PSE leaves the cable unpowered (idle state) while it periodically looks to see if something has been plugged in; this is referred to as detection. The low power levels used during detection are unlikely to damage devices not designed for PoE. If a valid PD signature is present, the PSE may inquire how much power the PD requires; this is referred to as classification. Type 2 PSEs are required to do hardware classification. The PD may return the default 12.95W (often referred to as 13W) current-encoded class, or one of four other choices. The PSE may then power the PD if it has adequate capacity. Once started, the PD must present the maintain power signature (MPS) to assure the PSE that it is still present. The PSE monitors its output for a valid MPS, and turns the port off if it loses the MPS. Loss of the MPS returns the PSE to the idle state. [Figure 16](#) shows the operational states as a function of PD input voltage.

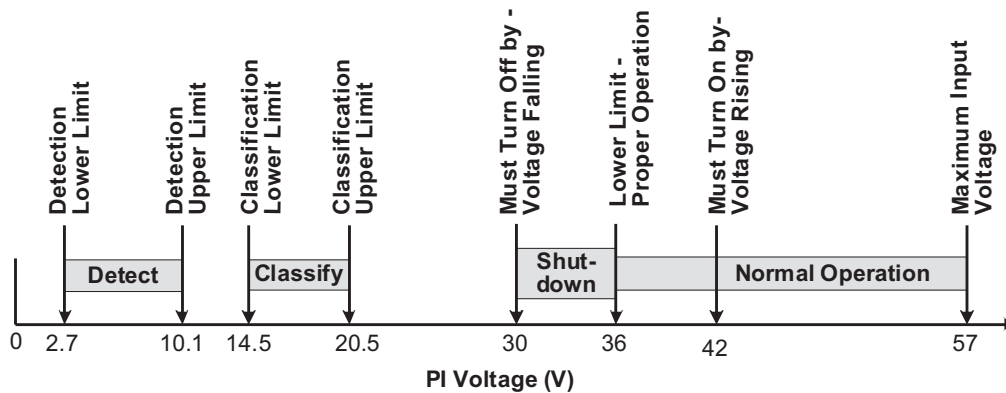

**Figure 16. IEEE 802.3-2005 (Type 1) Operational States**

The PD input is typically an RJ-45 eight-lead connector which is referred to as the power interface (PI). PD input requirements differ from PSE output requirements to account for voltage drops in the cable and operating margin. The IEEE 802.3-2005 standard uses a cable resistance of 20  $\Omega$  to derive the voltage limits at the PD based on the PSE output voltage requirements. Although the standard specifies an output power of 15.4 W at the PSE, only 12.95 W is available at the PI due to the worst-case power loss in the cable. The PSE can apply voltage either between the RX and TX pairs (pins 1–2 and 3–6 for 10baseT or 100baseT), or between the two spare pairs (4–5 and 7–8). The PSE may only apply voltage to one set of pairs at a time. The PD uses input diode bridges to accept power from any of the possible PSE configurations. The voltage drops associated with the input bridges create a difference between the standard limits at the PI and the TPS23753 specifications.

The PSE is permitted to disconnect a PD if it draws more than its maximum class power over a one second interval. A PSE compliant to IEEE 802.3-2005 is required to limit current to between 400 mA and 450 mA during powered operation, and it must disconnect the PD if it draws this current for more than 75 ms. Class 0 and 3 PDs may draw up to 400 mA peak currents for up to 50 ms. The PSE may set lower output current limits based on the PD's declared power requirements.

### Threshold Voltages

The TPS23753 has a number of internal comparators with hysteresis for stable switching between the various states as shown in [Figure 16](#). [Figure 17](#) relates the parameters in the Electrical Characteristics section to the PoE states. The mode labeled idle between classification and operation implies that the DEN, CLS, and RTN pins are all high impedance.

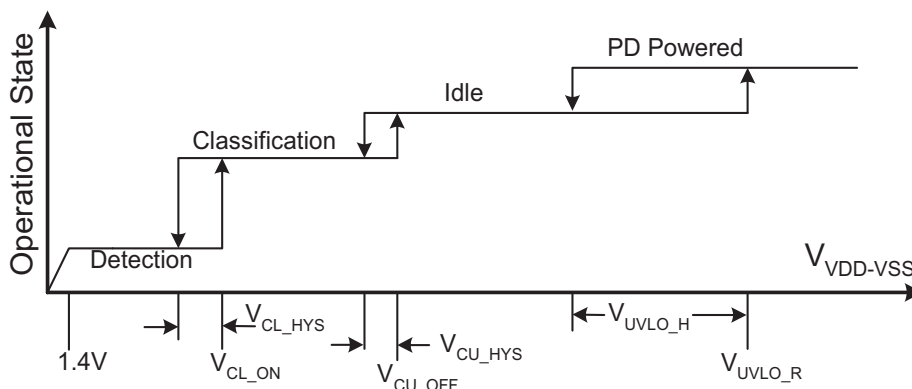

Note: Variable names refer to Electrical Characteristic Table parameters

Figure 17. Threshold Voltages

### PoE Startup Sequence

The waveforms of Figure 18 demonstrate detection, classification, and startup from a PSE. The key waveforms shown are  $V_{VDD-VSS}$ ,  $V_{RTN-VSS}$ , and  $I_{PI}$ . IEEE 802.3-2005 requires a minimum of two detection levels, however four levels are shown in this example. Four levels guard against misdetection of a device when plugged in during the detection sequence.

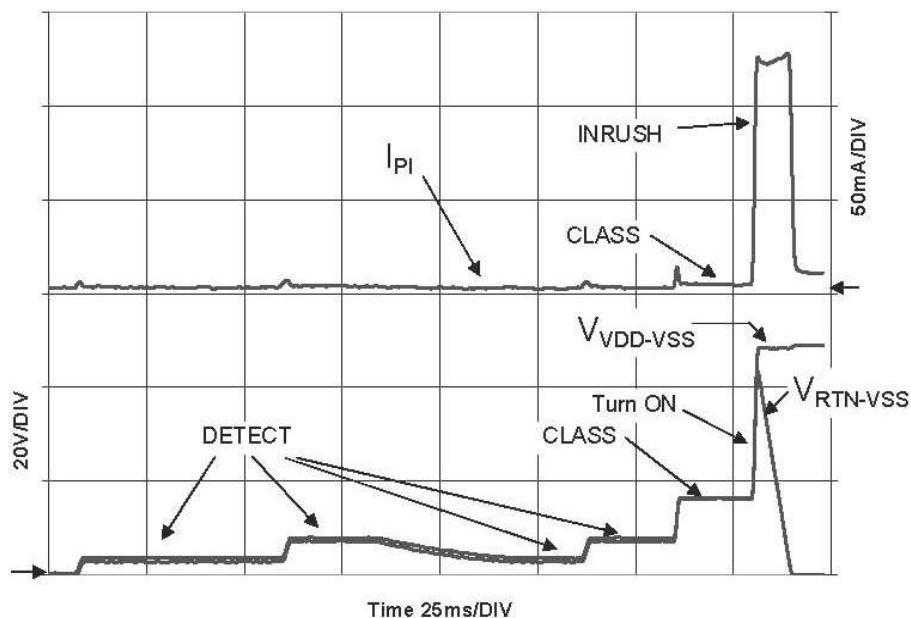

Figure 18. PoE Startup Sequence

### Detection

The TPS23753 is in detection mode whenever  $V_{VDD-VSS}$  is below the lower classification threshold. When the input voltage rises above  $V_{CL\_ON}$ , the DEN pin goes to an open-drain condition to conserve power. While in detection, RTN is high impedance, almost all the internal circuits are disabled, and the DEN pin is pulled to  $V_{SS}$ . An  $R_{DEN}$  of 24.9 k $\Omega$  (1%), presents the correct signature. It may be a small, low-power resistor since it only sees a stress of about 5 mW. A valid PD detection signature is an incremental resistance between 23.75 k $\Omega$  and 26.25 k $\Omega$  at the PI.

The detection resistance seen by the PSE at the PI is the result of the input bridge resistance in series with the parallel combination of  $R_{DEN}$  and the TPS23753 bias loading. The input diode bridge's incremental resistance may be hundreds of Ohms at the very low currents drawn when 2.7 V is applied to the PI. The input bridge resistance is partially cancelled by the TPS23753's effective resistance during detection.

## Hardware Classification

Hardware classification allows a PSE to determine a PD's power requirements before starting and helps with power management once power is applied. The maximum power entries in [Table 2](#) determine the class the PD must advertise. A Type 1 PD may not advertise Class 4. The PSE may disconnect a PD if it draws more than its stated Class power. The standard permits the PD to draw limited current peaks, however the average power requirement always applies.

Voltage between 14.5 V and 20.5 V is applied to the PD for up to 75 ms during hardware Classification. A fixed output voltage is sourced by the CLS pin, causing a fixed current to be drawn from  $V_{DD}$  through  $R_{CLS}$ . The total current drawn from the PSE during classification is the sum of bias and  $R_{CLS}$  currents. PD current is measured and decoded by the PSE to determine which of the five available classes is advertised (see [Table 2](#)). The TPS23753 disables classification above  $V_{CU\_OFF}$  to avoid excessive power dissipation. CLS voltage is turned off during PD thermal limit or when APD or DEN are active. The CLS output is inherently current limited, but should not be shorted to  $V_{SS}$  for long periods of time.

**Table 2. Class Resistor Selection**

CLASS	POWER AT PD PI		Class Current Requirement		RESISTOR ( $\Omega$ )	NOTES
	MINIMUM (W)	MAXIMUM (W)	MINIMUM (mA)	MAXIMUM (mA)		
0	0.44	12.95	0	4	1270	
1	0.44	3.84	9	12	243	
2	3.84	6.49	17	20	137	
3	6.49	12.95	26	30	90.9	
4	12.95	25.5	36	44	63.4	802.3at only, not allowed for IEEE 802.3-2005 (type 1 devices)

## Maintain Power Signature (MPS)

The MPS is an electrical signature presented by the PD to assure the PSE that it is still present after operating voltage is applied. A valid MPS consists of a minimum dc current of 10 mA (at a duty cycle of at least 75 ms on every 225 ms) and an ac impedance lower than 26.25 k $\Omega$  in parallel with 0.05  $\mu$ F. The ac impedance is usually accomplished by the minimum  $C_{IN}$  requirement of 5  $\mu$ F. When APD or DEN are used to force the hotswap switch off, the dc MPS will not be met. A PSE that monitors the dc MPS will remove power from the PD when this occurs. A PSE that monitors only the ac MPS may remove power from the PD.

## TPS23753 Operation

### Startup and Converter Operation

The internal PoE UVLO (Under Voltage Lock Out) circuit holds the hotswap switch off before the PSE provides full voltage to the PD. This prevents the converter circuits from loading the PoE input during detection and classification. The converter circuits will discharge  $C_{IN}$ ,  $C_{VC}$ , and  $C_{VB}$  while the PD is unpowered. Thus  $V_{RTN-VDD}$  will be a small voltage just after full voltage is applied to the PD, as seen in [Figure 18](#).

The PSE drives the PI voltage to the operating range once it has decided to power up the PD. When  $V_{DD}$  rises above the UVLO turn-on threshold ( $V_{UVLO-R}$ , ~35 V) with RTN high, the TPS23753 enables the hotswap MOSFET with a ~140 mA (inrush) current limit. Refer to the waveforms of [Figure 19](#) for an example. Converter switching is disabled while  $C_{IN}$  charges and  $V_{RTN}$  falls from  $V_{DD}$  to nearly  $V_{SS}$ , however the converter startup circuit is allowed to charge  $C_{VC}$ . Once the inrush current falls about 10% below the inrush current limit, the PD control switches to the operational level (~450 mA) and converter switching is permitted.

Converter switching is allowed if the PD is not in inrush and the  $V_C$  under-voltage lock out (UVLO) permits it. Continuing the startup sequence shown in Figure 19,  $V_{VC}$  rises as the startup current source charges  $C_{VC}$  and M1 switching is inhibited by the status of the  $V_C$  UVLO. The  $V_B$  regulator powers the internal converter circuits as  $V_{VC}$  rises. Startup current is turned off, converter switching is enabled, and a softstart cycle starts when  $V_{VC}$  exceeds  $UVLO_1$  (~9 V).  $V_{VC}$  falls as it powers both the internal circuits and the switching MOSFET gate. If the converter control-bias output rises to support  $V_{VC}$  before it falls to  $UVLO_1 - UVLO_{1H}$  (~5.5 V), a successful startup occurs. Figure 19 shows a small droop in  $V_{VC}$  while the output voltage rises smoothly and a successful startup occurs.

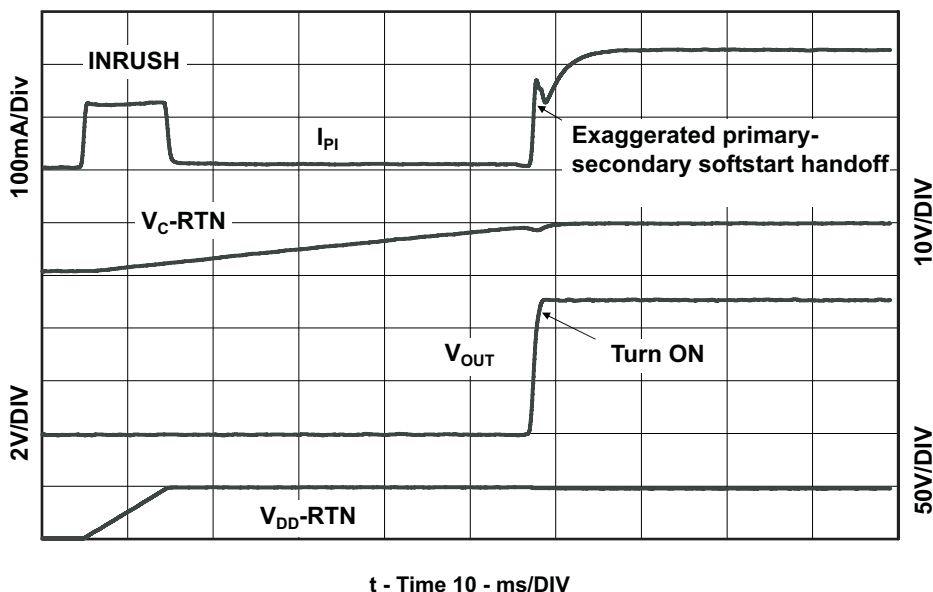

Figure 19. Power Up and Start

If  $V_{VDD-VSS}$  drops below the lower PoE UVLO ( $UVLO_R - UVLO_H$ , ~30.5 V), the hotswap MOSFET is turned off, but the converter will still run. The converter will stop if  $V_{VC}$  falls below the converter UVLO ( $UVLO_1 - UVLO_H$ , ~5.5 V), the hotswap is in inrush current limit, or 0% duty cycle is demanded by  $V_{CTL}$  ( $V_{CTL} < V_{ZDC}$ , ~1.5 V), or the converter is in thermal shutdown.

### PD Interface Features

The PD section has the following functions, with the first four covered above.

- Detection
- Classification
- $V_{DD}$  to  $V_{SS}$  UVLO
- Orderly sequencing of  $C_{IN}$  charge and converter operation
- Hotswap switch current limit
- Hotswap switch foldback
- Hotswap thermal protection

The internal hotswap MOSFET is protected against output faults with a current limit and deglitched foldback. The PSE output cannot be relied on to protect the PD MOSFET against transient conditions, so the PD implements its own protection. High stress conditions include converter output shorts, shorts from  $V_{DD}$  to RTN, or transients on the input line. An overload on the pass MOSFET engages the current limit, with  $V_{RTN-VSS}$  rising as a result. If  $V_{RTN}$  rises above ~12 V for longer than ~400  $\mu$ s, the current limit reverts to the inrush limit, and turns the converter off. The 400  $\mu$ s deglitch feature prevents momentary transients from causing a PD reset, provided that recovery lies within the bounds of the hotswap and PSE protection. Figure 20 shows an example of recovery from a 15 V PSE rising voltage step. The hotswap MOSFET goes into current limit, overshooting to a relatively low current, recovers to 420 mA full current limit, and charges the input capacitor while the converter continues to run. The MOSFET did not go into foldback because  $V_{RTN-VSS}$  was below 12 V after the 400  $\mu$ s deglitch.



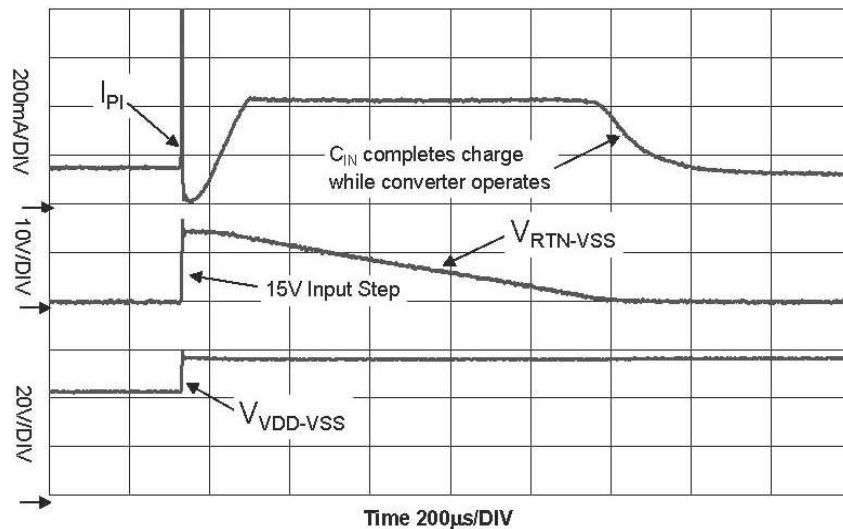

**Figure 20. Response to PSE Step Voltage**

The PD control has a thermal sensor that protects the internal hotswap MOSFET. Conditions like startup or operation into a  $V_{DD}$  to RTN short cause high power dissipation in the MOSFET. An overtemperature shutdown (OTSD) turns off the hotswap MOSFET and class regulator, which are restarted after the device cools. The PD state machine will always restart in inrush current limit when exiting from a PD overtemperature event.

Pulling DEN to  $V_{SS}$  during powered operation causes the internal hotswap MOSFET to turn off. This feature allows a PD with secondary-side adapter ORing to achieve adapter priority. Care must be taken with synchronous converter topologies that can deliver power in both directions.

The hotswap switch will be forced off under the following conditions:

- $V_{APD}$  above  $V_{APDEN}$  (~1.5 V)
- $V_{DEN} \leq V_{PD\_DIS}$  when  $V_{VDD-VSS}$  is in the operational range
- PD over temperature
- $V_{VDD-VSS} < \text{PoE UVLO}$  (~30.5 V).

### Converter Controller Features

The TPS23753 dc/dc controller implements a typical current-mode control as shown in [Figure 2](#). Features include oscillator, overcurrent and PWM comparators, current-sense blanker, softstart, and gate driver. In addition, an internal current-compensation ramp generator, frequency synchronization logic, thermal shutdown, and startup current source with control are provided.

The TPS23753 is optimized for isolated converters, and does not provide an internal error amplifier. Instead, the optocoupler feedback is directly fed to the CTL pin which serves as a current-demand control for the PWM and converter. There is an offset of  $V_{ZDC}$  (~1.5 V) and 2:1 resistor divider between the CTL pin and the PWM. A  $V_{CTL}$  below  $V_{ZDC}$  will stop converter switching, while voltages above  $(V_{ZDC} + 2 \times V_{CSMAX})$  will not increase the requested peak current in the switching MOSFET. Optocoupler biasing design is eased by this limited control range.

The internal startup current source and control logic implement a bootstrap-type startup. The startup current source charges  $C_{VC}$  from  $V_{DD1}$  when the converter is disabled (either by the PD control or the  $V_C$  control), while operational power must come from a converter (bias winding) output. Loading on  $V_C$  and  $V_B$  must be minimal while  $C_{VC}$  charges, otherwise the converter may never start. The optocoupler will not load  $V_B$  when the converter is off. The converter will shut off when  $V_C$  falls below its lower UVLO. This can happen when power is removed from the PD, or during a fault on a converter output rail. When one output is shorted, all the outputs fall in voltage including the one that powers  $V_C$ . The control circuit discharges  $V_C$  until it hits the lower UVLO and turns off. A restart will initiate as described in "Startup and Converter Operation" if the converter turns off and there is sufficient  $V_{DD1}$  voltage. This type of operation is sometimes referred to as "hiccup mode," which provides robust output short protection by providing time-average heating reduction of the output rectifier.



Care in design of the transformer and  $V_C$  bias circuit is required to obtain hiccup overload protection. Leading-edge voltage overshoot on the bias winding may cause  $V_C$  to peak-charge, preventing the expected tracking with output voltage.  $R_{VC}$  (Figure 1) is often required slow the peak charging. Good transformer bias-to-output-winding coupling results in reduced overshoot and better voltage tracking.

The startup current source transitions to a resistance as  $(V_{DD1} - V_C)$  falls below 7 V, but will start the converter from 12 V adapters within  $t_{ST}$  ( $V_{DD1} \geq 10.2$ ,  $V \sim 85$  ms). The bootstrap source provides reliable startup from widely varying input voltages, and eliminates the continual power loss of external resistors. The startup current source will not charge above the maximum recommended  $V_{VC}$  if the converter is disabled and there is sufficient  $V_{DD1}$  to charge higher.

The peak current limit does not have duty cycle dependency unless  $R_S$  is used as shown in Figure 22 to increase slope compensation. This makes it easier to design the current limit to a fixed value.

The TPS23753 blanker timing is precise enough that the traditional R-C filters on CS can be eliminated. This avoids current-sense waveform distortion, which tends to get worse at light output loads. While the internally set blanking period is relatively precise, almost all converters will require their own blanking period. The TPS23753 provides the BLNK pin to allow this programming. There may be some situations or designers that prefer an R-C approach. The TPS23753 provides a pull-down on CS during the GATE off time to improve sensing when an R-C filter must be used. The CS input signal should be protected from nearby noisy signals like GATE drive and the MOSFET drain.

Converters require a softstart on the voltage error amplifier to prevent output overshoot on startup. Figure 21 shows a common implementation of a secondary-side softstart that works with the typical TL431 error amplifier shown in Figure 1. This secondary-side error amplifier will not become active until there is sufficient voltage on the secondary. The TPS23753 provides a primary-side softstart which persists long enough ( $\sim 800 \mu s$ ) for secondary side voltage-loop softstart to take over. The primary-side current-loop softstart controls the switching MOSFET peak current by applying a slowly rising ramp voltage to a second PWM control input. Figure 19 shows an exaggerated handoff between the primary and secondary-side softstart that is most easily seen in the  $I_{PI}$  waveform. The output voltage rises in a smooth monotonic fashion with no overshoot. This handoff can be optimized by decreasing the secondary-side softstart period.

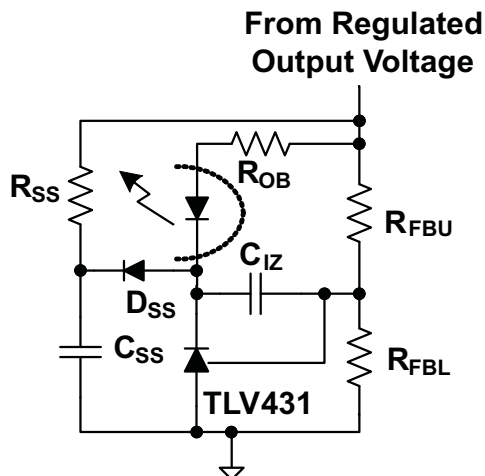

Figure 21. Example of Softstart Circuit Added to Error Amplifier

The dc/dc controller has an OTSD that can be triggered by heat sources including the  $V_B$  regulator, GATE driver, bootstrap current source, and bias currents. The controller OTSD turns off  $V_B$ , the GATE driver, resets the softstart generator, and forces the  $V_C$  control into an under-voltage state.

### Special Switching MOSFET Considerations

Special care must be used in selecting the converter switching MOSFET. The TPS23753 converter section has minimum  $V_C$  operating voltage of  $\sim 5.5$  V, which is reflected in the applied gate voltage. This will occur during an output overload, or towards the end of a (failed) bootstrap startup. The MOSFET must be able to carry the anticipated peak fault current at this gate voltage.

## Thermal Considerations

Sources of nearby local PCB heating should be considered during the thermal design. Typical calculations assume that the TPS23753 is the only heat source contributing to the PCB temperature rise. It is possible for a normally operating TPS23753 device to experience an OTSD event if it is excessively heated by a nearby device.

## Blanking – $R_{BLNK}$

The TPS23753 BLNK feature permits programming of the blanking period with specified tolerance. Selection of the blanking period is often empirical because it is affected by parasitics and thermal effects of every device between the gate-driver and output capacitors.

There is a critical range of blanking period that is bounded on the short side by erratic operation, and on the long side by potentially harmful switching-MOSFET and output rectifier currents during a short circuit. The minimum blanking period prevents the current limit and PWM comparators from being falsely triggered by the inherent current “spike” that occurs when the switching MOSFET turns on. The maximum blanking period is bounded by the output rectifier's ability to withstand the currents experienced during a converter output short. A short on the flyback transformer secondary will cause very large peak MOSFET currents that are worsened by longer blanking periods. A long blanking time also increases the minimum load required before cycle skipping occurs in a non-synchronous converter.

The TPS23753 provides a choice between internal fixed and programmable blanking periods. The blanking period is specified as an increase in the minimum GATE on time over the inherent gate driver and comparator delays. The default period (see the Electrical Characteristics table) is selected by connecting BLNK to RTN, and the programmable period is set with a resistor from BLNK to RTN per the following equation.

$$R_{BLNK} (k\Omega) = t_{BLNK} (ns) \quad (5)$$

For example, a 100 ns period is programmed by a 100 k $\Omega$  resistor. For a brand-new design, it is recommended that an initial blanking period of 125 ns be designed in. This period should be tuned once the converter is operational.

## Current Slope Compensation

Current-mode control requires addition of a compensation ramp to the sensed inductor (flyback transformer) current for stability at duty cycles near and over 50%. The TPS23753 has a maximum duty cycle limit of 80%, permitting the design of wide input-range flyback converters with a lower voltage stress on the output rectifiers. While the maximum duty cycle is 80%, converters may be designed that run at duty cycles well below 80% for a narrower, 36 V to 57 V range. The TPS23753 provides a fixed internal compensation ramp that suffices for most applications.  $R_S$  (see [Figure 22](#)) may be used if the internally provided slope compensation is not enough. It works with ramp current ( $I_{PK} = I_{SL-EX}$ , ~40  $\mu$ A) that flows out of the CS pin when the MOSFET is on. The  $I_{PK}$  specification does not include the ~3  $\mu$ A fixed current that flows out of the CS pin.

Most current-mode control papers and application notes define the slope values in terms of  $V_{PP}/T_S$  (peak ramp voltage / switching period), however the electrical characteristics table specifies the slope peak ( $V_{SLOPE}$ ) based on an 80% duty cycle. Assuming that the desired slope,  $V_{SLOPE-D}$  (in mV/period), is based on the full period, compute  $R_S$  per the following equation where  $V_{SLOPE}$ ,  $D_{MAX}$ , and  $I_{SL-EX}$  are from the electrical characteristics table with voltages in mV, current in  $\mu$ A, and the duty cycle is unitless (e.g.  $D_{MAX} = 0.8$ ).

$$R_S(\Omega) = \frac{\left[ V_{SLOPE\_D}(mV) - \left( V_{SLOPE}(mV) / D_{MAX} \right) \right]}{I_{SL\_EX}(\mu A)} \cdot 1000 \quad (6)$$

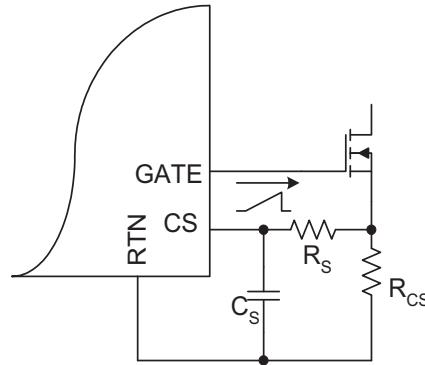

Figure 22. Additional Slope Compensation

C<sub>S</sub> may be required if the presence of R<sub>S</sub> causes increased noise, due to adjacent signals like the gate drive, to appear at the C<sub>S</sub> pin. The TPS23753 has an internal pull-down on C<sub>S</sub> (~500 Ω) while the MOSFET is OFF to reduce cycle-to-cycle carry-over voltage on C<sub>S</sub>.

### FRS and Synchronization

The FRS pin programs the (free-running) oscillator frequency, and may also be used to synchronize the TPS23753 converter to a higher frequency. The internal oscillator sets the maximum duty cycle at 80% and controls the current-compensation ramp circuit. R<sub>FRS</sub> should be selected per the following equation.

$$R_{FRS}(k\Omega) = \frac{15000}{f_{SW}(kHz)}$$

The TPS23753 may be synchronized to an external clock to eliminate beat frequencies from a sampled system, or to place emission spectrum away from an RF input frequency. Synchronization may be accomplished by applying a short pulse (> 25 ns) of magnitude V<sub>SYNC</sub> to FRS as shown in Figure 23. R<sub>FRS</sub> should be chosen so that the maximum free-running frequency is just below the desired synchronization frequency. The synchronization pulse terminates the potential on-time period, and the off-time period doesn't begin until the pulse terminates. A short pulse is preferred to avoid reducing the potential on-time.

Figure 23 shows examples of non-isolated and transformer-coupled synchronization circuits. The pulse at the FRS pin should reach between 2.5 V and V<sub>B</sub>, with a minimum width of 22 ns (above 2.5 V) and rise/fall times less than 10 ns. The FRS node should be protected from noise because it is high-impedance.

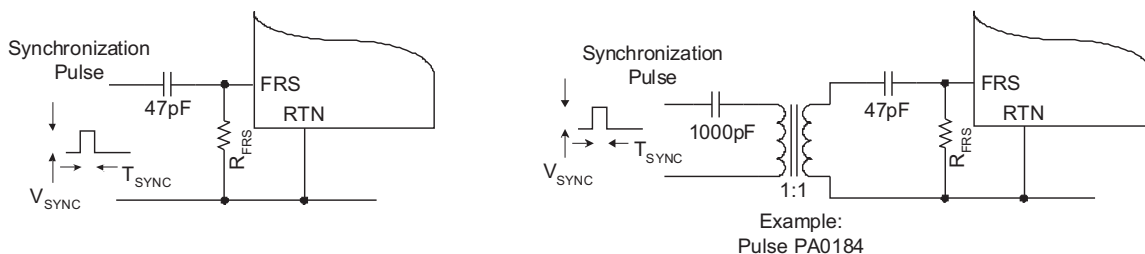
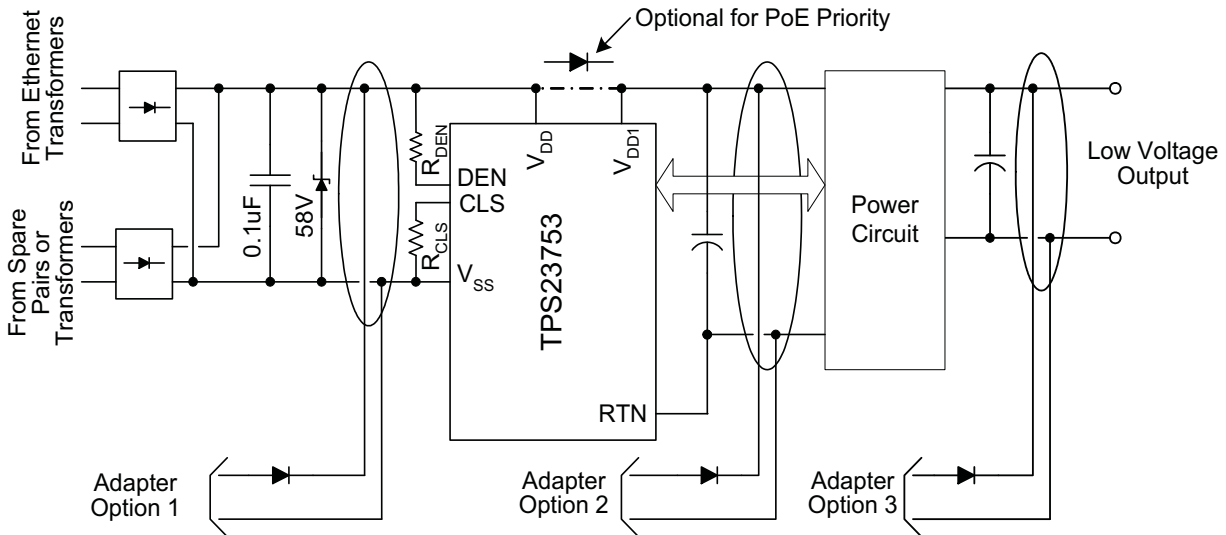

Figure 23. Synchronization

### Adapter ORing

Many PoE-capable devices are designed to operate from either a wall adapter or PoE power. A local power solution adds cost and complexity, but allows a product to be used if PoE is not available in a particular

installation. While most applications only require that the PD operate when both sources are present, the TPS23753 supports forced operation from either of the power sources. Figure 24 illustrates three options for diode ORing external power into a PD. Only one option would be used in any particular design. Option 1 applies power to the TPS23753 PoE input, option 2 applies power between the TPS23753 PoE section and the power circuit, and option 3 applies power to the output side of the converter. Each of these options has advantages and disadvantages. A detailed discussion of the TPS23753 and ORing solutions is covered in application note *Advanced Adapter ORing Solutions using the TPS23753*, literature number [SLVA306](#).



**Figure 24. ORing Configurations**

Preference of one power source presents a number of challenges. Combinations of adapter output voltage (nominal and tolerance), power insertion point, and which source is preferred determine solution complexity. Several factors which add to the complexity are the natural high-voltage selection of diode ORing (the simplest method of combining sources), the current limit implicit in the PSE, and PD inrush and protection circuits (necessary for operation and reliability). Creating simple and seamless solutions is difficult if not impossible for many of the combinations. However the TPS23753 offers several built-in features that simplify some combinations.

Several examples will demonstrate the limitations inherent in ORing solutions. Diode ORing a 48 V adapter with PoE (option 1) presents the problem that either source might be higher. A blocking switch would be required to assure which source was active. A second example is combining a 12 V adapter with PoE using option 2. The converter will draw approximately four times the current at 12 V from the adapter than it does from PoE at 48 V. Transition from adapter power to PoE may demand more current than can be supplied by the PSE. The converter must be turned off while  $C_{IN}$  capacitance charges, with a subsequent converter restart at the higher voltage and lower input current. A third example is use of a 12 V adapter with ORing option 1. The PD hotswap would have to handle four times the current, and have 1/16 the resistance (be 16 times larger) to dissipate equal power. A fourth example is that MPS is lost when running from the adapter, causing the PSE to remove power from the PD. If ac power is then lost, the PD will stop operating until the PSE detects and powers the PD.

The most popular preferential ORing scheme is option 2 with adapter priority. The hotswap MOSFET is disabled when the adapter is used to pull APD high, blocking the PoE source from powering the output. This solution works well with a wide range of adapter voltages, is simple, and requires few external parts. When the ac power fails, or the adapter is removed, the hotswap switch is enabled. In the simplest implementation, the PD will momentarily lose power until the PSE completes its startup cycle.

The DEN pin can be used to disable the PoE input when ORing with option 3. This is an adapter priority implementation. Pulling DEN low, while creating an invalid detection signature, disables the hotswap MOSFET and prevents the PD from redetecting. This would typically be accomplished with an optocoupler that is driven from the secondary side of the converter.

The least popular technique is PoE priority. It is implemented by placing a diode between the PD supply voltage,  $V_{DD}$ , and the dc/dc controller bias voltage,  $V_{DD1}$ . The diode prevents reverse biasing of the PoE input diode bridges when option 2 adapter ORing is used. The PSE may then detect, classify, and provide power to the PD while a live adapter is connected. As long as the PoE voltage is greater than the adapter voltage, the PSE will power the load. The APD function is not used in this technique.

The IEEE standards require that the Ethernet cable be isolated from ground and all other system potentials. The adapter must meet a minimum 1500 Vac dielectric withstand test between the output and all other connections for options 1 and 2. The adapter only needs this isolation for option 3 if it is not provided by the converter.

Adapter ORing diodes are shown for all the options to protect against a reverse voltage adapter, a short on the adapter input pins, and damage to a low-voltage adapter. ORing is sometimes accomplished with a MOSFET in option 3.

## Protection

A TVS across the rectified PoE voltage per [Figure 1](#) must be used. An SMAJ58A, or a part with equal to or better performance, is recommended for general indoor applications. If an adapter is connected from  $V_{DD1}$  to RTN, as in ORing option 2 above, voltage transients caused by the input cable inductance ringing with the internal PD capacitance can occur. Adequate capacitive filtering or a TVS must limit this voltage to be within the absolute maximum ratings

Outdoor applications require more extensive protection to lightning standards.

## Frequency Dithering for Conducted Emissions Control

The international standard CISPR 22 (and adopted versions) is often used as a requirement for conducted emissions. Ethernet cables are covered as a telecommunication port under section 5.2 for conducted emissions. Meeting EMI requirements is often a challenge, with the lower limits of Class B being especially hard. Circuit board layout, filtering, and snubbing various nodes in the power circuit are the first layer of control techniques. A more detailed discussion of EMI control is presented in *Practical Guidelines to Designing an EMI Compliant PoE Powered Device With Isolated Flyback*, TI literature number [SLUA469](#). Additionally, IEEE802.3-2005 section 33.4 has requirements for noise injected onto the Ethernet cable based on compatibility with data transmission.

Occasionally, a technique referred to as frequency dithering is utilized to provide additional EMI measurement reduction. The switching frequency is modulated to spread the narrowband individual harmonics across a wider bandwidth, thus lowering peak measurements. The circuit of [Figure 25](#) modulates the switching frequency by feeding a small ac signal into the FRS pin. These values may be adapted to suit individual needs.

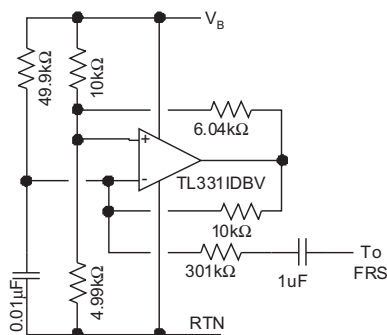

Figure 25. Frequency Dithering

## Design Procedure

A detailed design procedure for PDs using the TPS23753 is covered in *Designing with the TPS23753 Powered Device and Power Supply Controller*, literature number [SLVA305](#).

## References

*IEEE Standard for Information Technology ... Part 3: Carrier sense multiple access with collision detection (CSMA/CD) access method and physical layer specifications*, IEEE Computer Society, IEEE 802.3™-2005 (Clause 33)

*Information technology equipment – Radio disturbance characteristics – Limits and methods of measurement*, International Electrotechnical Commission, CISPR 22 Edition 5.2, 2006-03

*Designing with the TPS23753 Powered Device and Power Supply Controller*, Eric Wright, TI, [SLVA305](#)

*Advanced Adapter ORing Solutions using the TPS23753*, Eric Wright, TI, [SLVA306](#)

*Practical Guidelines to Designing an EMI-Compliant PoE Powered Device With Isolated Flyback*, Donald V. Comiskey, TI, [SLUA469](#)

**PACKAGING INFORMATION**

Orderable Device	Status <sup>(1)</sup>	Package Type	Package Drawing	Pins	Package Qty	Eco Plan <sup>(2)</sup>	Lead/Ball Finish	MSL Peak Temp <sup>(3)</sup>
TPS23753PW	ACTIVE	TSSOP	PW	14	90	Green (RoHS & no Sb/Br)	CU NIPDAU	Level-1-260C-UNLIM
TPS23753PWG4	ACTIVE	TSSOP	PW	14	90	Green (RoHS & no Sb/Br)	CU NIPDAU	Level-1-260C-UNLIM
TPS23753PWR	ACTIVE	TSSOP	PW	14	2000	Green (RoHS & no Sb/Br)	CU NIPDAU	Level-1-260C-UNLIM
TPS23753PWRG4	ACTIVE	TSSOP	PW	14	2000	Green (RoHS & no Sb/Br)	CU NIPDAU	Level-1-260C-UNLIM

<sup>(1)</sup> The marketing status values are defined as follows:

**ACTIVE:** Product device recommended for new designs.

**LIFEBUY:** TI has announced that the device will be discontinued, and a lifetime-buy period is in effect.

**NRND:** Not recommended for new designs. Device is in production to support existing customers, but TI does not recommend using this part in a new design.

**PREVIEW:** Device has been announced but is not in production. Samples may or may not be available.

**OBSOLETE:** TI has discontinued the production of the device.

<sup>(2)</sup> Eco Plan - The planned eco-friendly classification: Pb-Free (RoHS), Pb-Free (RoHS Exempt), or Green (RoHS & no Sb/Br) - please check <http://www.ti.com/productcontent> for the latest availability information and additional product content details.

**TBD:** The Pb-Free/Green conversion plan has not been defined.

**Pb-Free (RoHS):** TI's terms "Lead-Free" or "Pb-Free" mean semiconductor products that are compatible with the current RoHS requirements for all 6 substances, including the requirement that lead not exceed 0.1% by weight in homogeneous materials. Where designed to be soldered at high temperatures, TI Pb-Free products are suitable for use in specified lead-free processes.

**Pb-Free (RoHS Exempt):** This component has a RoHS exemption for either 1) lead-based flip-chip solder bumps used between the die and package, or 2) lead-based die adhesive used between the die and leadframe. The component is otherwise considered Pb-Free (RoHS compatible) as defined above.

**Green (RoHS & no Sb/Br):** TI defines "Green" to mean Pb-Free (RoHS compatible), and free of Bromine (Br) and Antimony (Sb) based flame retardants (Br or Sb do not exceed 0.1% by weight in homogeneous material)

<sup>(3)</sup> MSL, Peak Temp. -- The Moisture Sensitivity Level rating according to the JEDEC industry standard classifications, and peak solder temperature.

**Important Information and Disclaimer:**The information provided on this page represents TI's knowledge and belief as of the date that it is provided. TI bases its knowledge and belief on information provided by third parties, and makes no representation or warranty as to the accuracy of such information. Efforts are underway to better integrate information from third parties. TI has taken and continues to take reasonable steps to provide representative and accurate information but may not have conducted destructive testing or chemical analysis on incoming materials and chemicals. TI and TI suppliers consider certain information to be proprietary, and thus CAS numbers and other limited information may not be available for release.

In no event shall TI's liability arising out of such information exceed the total purchase price of the TI part(s) at issue in this document sold by TI to Customer on an annual basis.



**TAPE AND REEL INFORMATION**



**QUADRANT ASSIGNMENTS FOR PIN 1 ORIENTATION IN TAPE**



\*All dimensions are nominal

Device	Package Type	Package Drawing	Pins	SPQ	Reel Diameter (mm)	Reel Width W1 (mm)	A0 (mm)	B0 (mm)	K0 (mm)	P1 (mm)	W (mm)	Pin1 Quadrant
TPS23753PWR	TSSOP	PW	14	2000	330.0	12.4	7.0	5.6	1.6	8.0	12.0	Q1



**TAPE AND REEL BOX DIMENSIONS**



\*All dimensions are nominal

Device	Package Type	Package Drawing	Pins	SPQ	Length (mm)	Width (mm)	Height (mm)
TPS23753PWR	TSSOP	PW	14	2000	346.0	346.0	29.0

PW (R-PDSO-G\*\*)

PLASTIC SMALL-OUTLINE PACKAGE

14 PINS SHOWN



4040064/F 01/97

- NOTES: A. All linear dimensions are in millimeters.  
 B. This drawing is subject to change without notice.  
 C. Body dimensions do not include mold flash or protrusion not to exceed 0,15.  
 D. Falls within JEDEC MO-153

## IMPORTANT NOTICE

Texas Instruments Incorporated and its subsidiaries (TI) reserve the right to make corrections, modifications, enhancements, improvements, and other changes to its products and services at any time and to discontinue any product or service without notice. Customers should obtain the latest relevant information before placing orders and should verify that such information is current and complete. All products are sold subject to TI's terms and conditions of sale supplied at the time of order acknowledgment.

TI warrants performance of its hardware products to the specifications applicable at the time of sale in accordance with TI's standard warranty. Testing and other quality control techniques are used to the extent TI deems necessary to support this warranty. Except where mandated by government requirements, testing of all parameters of each product is not necessarily performed.

TI assumes no liability for applications assistance or customer product design. Customers are responsible for their products and applications using TI components. To minimize the risks associated with customer products and applications, customers should provide adequate design and operating safeguards.

TI does not warrant or represent that any license, either express or implied, is granted under any TI patent right, copyright, mask work right, or other TI intellectual property right relating to any combination, machine, or process in which TI products or services are used. Information published by TI regarding third-party products or services does not constitute a license from TI to use such products or services or a warranty or endorsement thereof. Use of such information may require a license from a third party under the patents or other intellectual property of the third party, or a license from TI under the patents or other intellectual property of TI.

Reproduction of TI information in TI data books or data sheets is permissible only if reproduction is without alteration and is accompanied by all associated warranties, conditions, limitations, and notices. Reproduction of this information with alteration is an unfair and deceptive business practice. TI is not responsible or liable for such altered documentation. Information of third parties may be subject to additional restrictions.

Resale of TI products or services with statements different from or beyond the parameters stated by TI for that product or service voids all express and any implied warranties for the associated TI product or service and is an unfair and deceptive business practice. TI is not responsible or liable for any such statements.

TI products are not authorized for use in safety-critical applications (such as life support) where a failure of the TI product would reasonably be expected to cause severe personal injury or death, unless officers of the parties have executed an agreement specifically governing such use. Buyers represent that they have all necessary expertise in the safety and regulatory ramifications of their applications, and acknowledge and agree that they are solely responsible for all legal, regulatory and safety-related requirements concerning their products and any use of TI products in such safety-critical applications, notwithstanding any applications-related information or support that may be provided by TI. Further, Buyers must fully indemnify TI and its representatives against any damages arising out of the use of TI products in such safety-critical applications.

TI products are neither designed nor intended for use in military/aerospace applications or environments unless the TI products are specifically designated by TI as military-grade or "enhanced plastic." Only products designated by TI as military-grade meet military specifications. Buyers acknowledge and agree that any such use of TI products which TI has not designated as military-grade is solely at the Buyer's risk, and that they are solely responsible for compliance with all legal and regulatory requirements in connection with such use.

TI products are neither designed nor intended for use in automotive applications or environments unless the specific TI products are designated by TI as compliant with ISO/TS 16949 requirements. Buyers acknowledge and agree that, if they use any non-designated products in automotive applications, TI will not be responsible for any failure to meet such requirements.

Following are URLs where you can obtain information on other Texas Instruments products and application solutions:

### Products

Amplifiers	<a href="http://amplifier.ti.com">amplifier.ti.com</a>
Data Converters	<a href="http://dataconverter.ti.com">dataconverter.ti.com</a>
DSP	<a href="http://dsp.ti.com">dsp.ti.com</a>
Clocks and Timers	<a href="http://www.ti.com/clocks">www.ti.com/clocks</a>
Interface	<a href="http://interface.ti.com">interface.ti.com</a>
Logic	<a href="http://logic.ti.com">logic.ti.com</a>
Power Mgmt	<a href="http://power.ti.com">power.ti.com</a>
Microcontrollers	<a href="http://microcontroller.ti.com">microcontroller.ti.com</a>
RFID	<a href="http://www.ti-rfid.com">www.ti-rfid.com</a>
RF/IF and ZigBee® Solutions	<a href="http://www.ti.com/lprf">www.ti.com/lprf</a>

### Applications

Audio	<a href="http://www.ti.com/audio">www.ti.com/audio</a>
Automotive	<a href="http://www.ti.com/automotive">www.ti.com/automotive</a>
Broadband	<a href="http://www.ti.com/broadband">www.ti.com/broadband</a>
Digital Control	<a href="http://www.ti.com/digitalcontrol">www.ti.com/digitalcontrol</a>
Medical	<a href="http://www.ti.com/medical">www.ti.com/medical</a>
Military	<a href="http://www.ti.com/military">www.ti.com/military</a>
Optical Networking	<a href="http://www.ti.com/opticalnetwork">www.ti.com/opticalnetwork</a>
Security	<a href="http://www.ti.com/security">www.ti.com/security</a>
Telephony	<a href="http://www.ti.com/telephony">www.ti.com/telephony</a>
Video & Imaging	<a href="http://www.ti.com/video">www.ti.com/video</a>
Wireless	<a href="http://www.ti.com/wireless">www.ti.com/wireless</a>

Mailing Address: Texas Instruments, Post Office Box 655303, Dallas, Texas 75265  
Copyright © 2008, Texas Instruments Incorporated